

# HG4930 INERTIAL MEASUREMENT UNIT (IMU)

Installation and Interface Manual

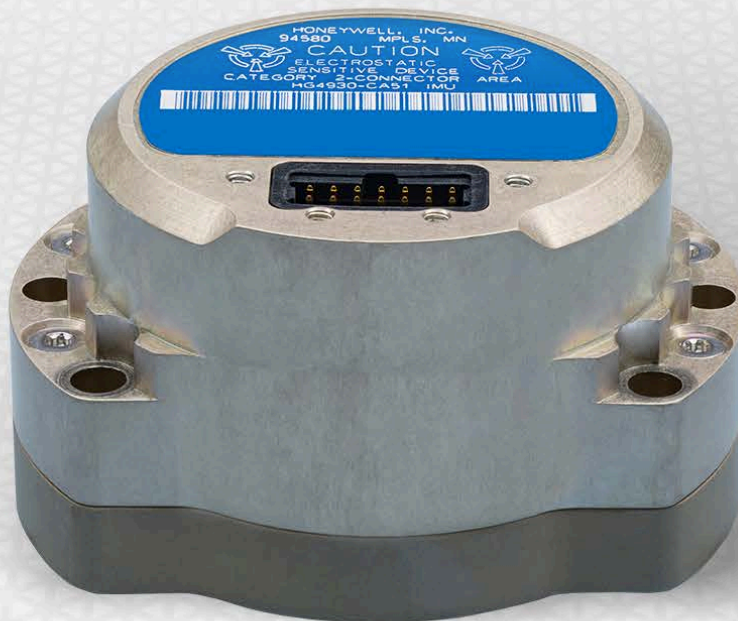

# Table of Contents

4	<a href="#">Honeywell Industrial Inertial Measurement Units</a>
5	<a href="#">Electrical Interface</a>
6	<a href="#">Asynchronous Protocol</a>
	<a href="#">General Description</a>
	<a href="#">Rotation Correction</a>
	<a href="#">Data Synchronization Signal</a>
10	<a href="#">Normal Operation Mode Description</a>
11	<a href="#">Mechanical Drawing and Installation</a>
13	<a href="#">Export Guidance</a>
13	<a href="#">Contact Us</a>

# Table of Tables

5	<a href="#">Table 1. Connector Pin Description</a>
5	<a href="#">Table 2. Input Power Specifications</a>
8	<a href="#">Table 3. Asynchronous Control Message (0x01 Format)</a>
8	<a href="#">Table 4. Asynchronous Control Message Field Status Word 1</a>
9	<a href="#">Table 5. Asynchronous Control Message Field Status Word 2A</a>
9	<a href="#">Table 6. Asynchronous Control Message Field Status Word 2B</a>
9	<a href="#">Table 7. Asynchronous Inertial Message (0x02 Format)</a>

# Table of Figures

- 5 [Figure 1. Figure 1. Typical Cold \(Left Figure\) and Hot Voltage/In-Rush Plots](#)
- 7 [Figure 2. Data Synchronization Signal Timing](#)
- 10 [Figure 3. Power Up Sequence](#)
- 11 [Figure 4. Accelerometer and Gyro Sensor Mounting](#)
- 12 [Figure 5. Installation Drawing](#)

# Honeywell Industrial Inertial Measurement Units



Honeywell produces no license required (NLR) Inertial Measurement Units (IMU) for industrial applications including agricultural vehicles, robotics, survey, mapping, and stabilized systems. These IMUs are designed for industrial application and can be used on air, land, and sea. Honeywell began producing gyros in the 1940's for the Honeywell C-1 autopilot and specifically began producing MEMS gyros and accelerometers in the early 2000's. Honeywell's IMUs utilize proprietary Honeywell technology and leverage existing production and engineering infrastructure. Honeywell has deep and long lasting relations with many commercial customers and is carrying that philosophy and product pedigree into our NLR IMU line. Honeywell's forward looking product strategies will ensure that our NLR IMU's will fit your current and future needs.

The HG4930 IMU is a device which measures angular rates and linear accelerations in a body mounted strapdown configuration. It will provide compensated incremental angle and velocity data for navigation as well as angular rates and linear accelerations for control. The data is reported through a digital serial interface bus. The unit contains MEMS gyroscopes and accelerometers as well as the electronics and software necessary to deliver precision control and navigation information. The input axes form a right handed frame aligned with the IMU mounting frame.

# Electrical Interface

The pin assignments of the external system connector are shown below. **Logic 0 corresponds to the CMOS “low” logic state. Logic 1 corresponds to the CMOS “high” logic state.**

**Table 1. Connector Pin Description**

PIN #	SIGNAL NAME	INPUT/OUTPUT & SIGNAL TYPE	SIGNAL FUNCTION
1	DGND	Ground	Digital Power and Signal Return
2	+5VDC	Input	+ 5 VDC Power – See Table 2
3	No Connect		
4	No Connect		
5	No Connect		
6	RESET	Input CMOS Compatible Logic	Logic 1 applied for 7 milli-seconds will stop all processing. Upon logic 0, the IMU will restart as if power had been removed. No connection is required (active pull down to logic 0).
7	No Connect		
8	No Connect		
9	SER_DATA_OUT_H	Output RS-422	Asynchronous High
10	SER_DATA_OUT_L	Output RS-422	Asynchronous Low
11	DATA_SYNC_OUT_H	Output RS-422	Data Sync High
12	DATA_SYNC_OUT_L	Output RS-422	Data Sync Low
13	No Connect		
14	No Connect		

**Table 2. Input Power Specifications**

VOLTAGE (VDC)	TOLERANCE	MAX RIPPLE (MV P-P)	MAX RUN CURRENT (AMP)	MAX CURRENT (MA)
+5	±5%	50	1.0	700

The 5V power application to the IMU must monotonically increase from 1 to 5 volts for proper IMU start-up. The maximum current shown in Table 2 does not include in-rush current.

Figure 1 provides representative voltage and current plots at hot and cold for a ~2ms start time. Worse case steady state current shown is ~500 mA (cold) and peak current shown is ~800 mA. Unit typically draws < 400 mA in normal operation.

**Figure 1. Typical Cold (Left Figure) and Hot Voltage/In-Rush Plots**



# Asynchronous Protocol

## General Description

The IMU supports the asynchronous RS-422 compatible protocol. Each Asynchronous output frame will open with an IMU address byte that can be used as a syncing byte.

The asynchronous 600/100 Hz data protocol is as specified in Table 3 – Control Message (0x01) Format and Table 7 – Inertial Message (0x02) Format.

The start of sequential message transmissions is on the average  $1/600$  seconds  $\pm 0.01\%$  apart, with a repeating pattern of five control message transmissions followed by one inertial message transmission.

The 600 Hz control data output consists of the angular rates, linear acceleration, and IMU status words in message ID 0x01 and 0x02. The angular and linear data is filtered and sampled at 1800 Hz. The 1800 Hz filtered angular and linear data is decimated for 600 Hz control data.

The 100 Hz navigation data output consists of incremental (or “delta”) angles and velocities in message ID 0x02. The navigation data is unfiltered 1800 Hz sensor data which is summed to the navigation data rate (100 Hz). Accurate attitude and position calculations require that all messages be received and used.

The order of transmission is Least Significant (LS) bit first; LS byte first; LS 16 bit word first. Only gyro, accelerometer, and temperature data is signed.

The transmit baud rate will be 1Mbits/sec with 1 start bit, 8 data bits, 1 stop bit, and no parity.

## Rotation Correction

The IMU shall subtract the “rotation correction” from the inertial delta-velocity components of message ID 0x02 to allow direct integration of the synchronously sampled body-axis delta-angle and delta-velocity elements. The “rotation correction” consists of one half of the sampled delta-angle vector cross the sampled delta-velocity vector.

$$\Delta\theta_{\text{Asynchronous}} = \Delta\theta \text{ SAMPLE}$$

$$\Delta V_{\text{Asynchronous}} = \Delta V \text{ SAMPLE} - 0.5 * [\Delta\theta \text{ SAMPLE} \times \Delta V \text{ SAMPLE}]$$

As a result of the subtraction, proper integration of local-vertical navigation components will require update of the body-to-local-vertical attitude reference, transformation of the body-axis delta-velocity components to the local-vertical frame followed by update of the local-vertical attitude components.

## Data Synchronization Signal

The Data Synchronization Signal shall be an active low pulse with the following characteristics:

- Pulse start is within +/- 1 microsecond of the most recent data sample event in the Control data frame.
- Pulse width is 300 microseconds +/- 1 microsecond

The signal timing is shown in Figure 3 - Data Synchronization Signal Timing.

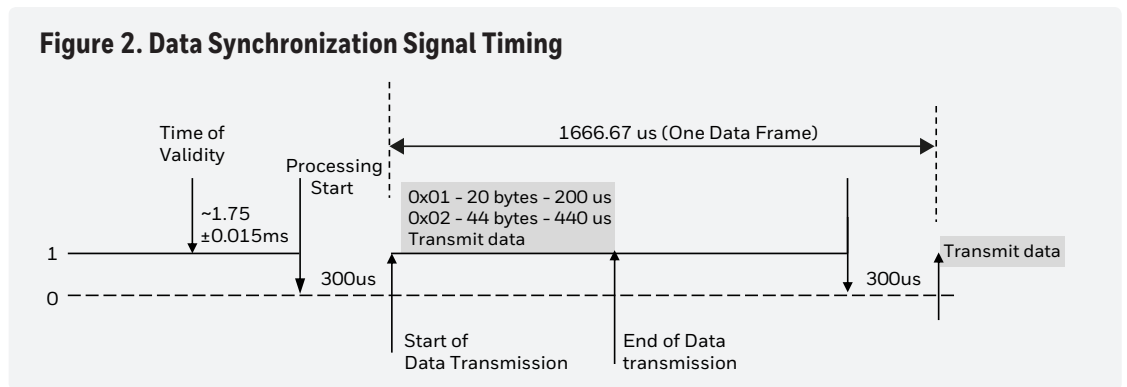

**Table 3. Asynchronous Control Message (0x01 Format)**

POSITION	PARAMETER	LENGTH (BYTES)	LSB WEIGHT	UNITS OR CONTENTS
1	IMU Address	1	N/A	Constant 0x0E
2	Message ID	1	N/A	Constant 0x01
3	Angular Rate X	2	$2^{-20} * 600$	rad/sec/LSB
4	Angular Rate Y	2	$2^{-20} * 600$	rad/sec/LSB
5	Angular Rate Z	2	$2^{-20} * 600$	rad/sec/LSB
6	Linear Acceleration X	2	$2^{-14} * 600$	0.3048 meters/sec <sup>2</sup> /LSB
7	Linear Acceleration Y	2	$2^{-14} * 600$	0.3048 meters/sec <sup>2</sup> /LSB
8	Linear Acceleration Z	2	$2^{-14} * 600$	0.3048 meters/sec <sup>2</sup> /LSB
9	Status 1	2	N/A	See Table 4
10	Status 2A or 2B	2	N/A	See Table 5 and 6
11	Checksum	2	N/A	// this pseudo code illustrates the checksum algorithm
Sum of all message data (positions 1...10 of this table), taken as 16 bit words, and summed without regard for rollover.				<pre> u16sum = 0; for (i=0; i&lt;9; i++) // (20-2)/2=9 { u16sum += u16_msg_array[i]; } Checksum = u16_msg_array[9]; if (Checksum != u16sum) {checksum error}                     </pre>
<b>Total Length</b>		<b>20</b>		

**Table 4. Asynchronous Control Message Field Status Word 1**

BIT	DEFINITION	NOTES
Bit 0-1	2 Bit Counter	00 01 10 11...
Bit 2-3	2 bit BIT-mode indicator	0=Power-up BIT 1=Continuous BIT 2-3 = Reserved
Bit 4	IMU	0=OK, 1=Failed
Bit 5	Gyro	These fault monitors are aggregate and latched (continue after the failure has stopped) but will only latch after a lower level test has failed. The latching logic may require multiple consecutive failures before setting. These latched failures are cleared after power up or reset.
Bit 6	Accelerometer	
Bits 7-10	Gyro Sensor	
Bits 7-10	Gyro Sensor	0=OK, 1=Failed Bit 7 checks sensor voltage levels. Bits 8-10 check that Gyros X, Y, and Z are individually functioning.
Bit 11-14	Reserved	N/A
Bit 15	IMU OK	0=OK, 1=Failed



**Table 5. Asynchronous Control Message Field Status Word 2A**

BIT	DEFINITION	NOTES
Bit 0-7	Software Version Number	
Bit 8	Gyro Health	0=OK, 1=Failed
Bit 9	Start data flag	0=sensor data, 1=0x5555 data transmitted for synchronization
Bit 10	Process Test	0=OK, 1=Failed
Bit 11	Memory Test	0=OK, 1=Failed
Bit 12	Electronics Test (ASIC)	0=OK, 1=Failed
Bit 13	Gyro Health	0=OK, 1=Failed
Bit 14	Accelerometer Health	0=OK, 1=Failed
Bit 15	Status Word 2X flag	0=2A

**Table 6. Asynchronous Control Message Field Status Word 2B**

BIT	DEFINITION	NOTES
Bit 0-7	Accelerometer X Temperature	LSB=1°C, Not Calibrated
Bits 8-14	Identical to Field Status Word 2A	See Table 5
Bit 15	Status Word 2X flag	1=2B

**Table 7. Asynchronous Inertial Message (0x02 Format)**

POSITION	PARAMETER	LENGTH (BYTES)	LSB WEIGHT	UNITS OR CONTENTS
1	IMU Address	1	N/A	Constant 0x0E
2	Message ID	1	N/A	Constant 0x02
3-10	Control Data	16	N/A	Contents same as Message 0x01 Positions 3-10.
11	Delta Angle X	4	$2^{-33}$	radians/LSB or equivalently, radians/second/Hz/LSB
12	Delta Angle Y	4	$2^{-33}$	
13	Delta Angle Z	4	$2^{-33}$	
14	Delta Velocity X	4	$2^{-27}$	0.3048 meters/sec/LSB or equivalently, 0.3048 meters/sec <sup>2</sup> /Hz/LSB
15	Delta Velocity Y	4	$2^{-27}$	
16	Delta Velocity Z	4	$2^{-27}$	
17	Checksum	2	N/A	// this pseudo code illustrates the checksum algorithm
Sum of all message data (positions 1-16 of this table), taken as 16 bit words, and summed without regard for rollover.				<pre> u16sum = 0; for (i=0; i&lt;21; i++) // (44-2)/2=21 { u16sum += u16_msg_array[i]; } Checksum = u16_msg_array[21]; if (Checksum != u16sum) {checksum error} </pre>
<b>Total Length</b>		<b>44</b>		

# Normal Operation Mode Description

The serial data interface is operational within 300 milliseconds after the last applied power form is within the specified tolerances and the reset line is inactive.

The IMU transmits a fixed pattern 0x5555 (Hex) in place of Control sensor data and 0x55555555 (Hex) in place of Inertial sensor data until the completion of Power Up BIT.

The IMU completes Power Up BIT and report the results within 400 milliseconds after power is within specified tolerances and IMU Reset is inactive.

**Figure 3. Power Up Sequence**

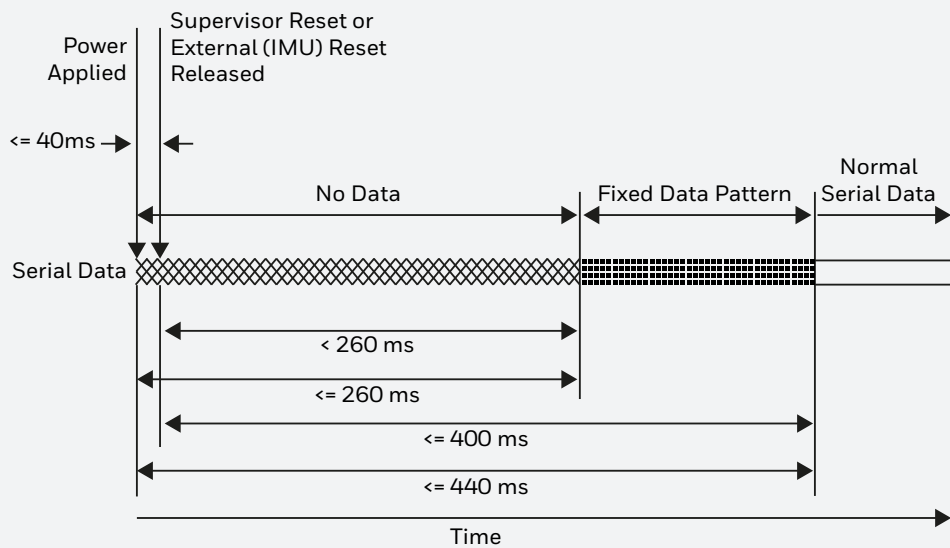

# Mechanical Drawing and Installation

A CAD compatible STP file is available from Honeywell upon request. The typical IMU weight is 140 grams (0.3 lbs).

Figure 5 lists installation notes which should be carefully reviewed. With regards to note 12 regarding SPIRALOCK threads - Honeywell recommends a #2-56 UNC 2B screw (2ea) torqued to 4.25 in-lbs for the I/O connector. Length is determined by evaluating the thickness of the mating connector assembly.

IMUs are precision instruments which measure angular rate and linear acceleration across a broad temperature range. Because of their precision, users can interpret real motion (both angular and linear) as sensor noise. This noise can often be coupled mechanically through the mounting plate. Installation on a thin structure is generally not desirable. Placement at anti-nodes will minimize angular rotation and maximize linear displacement. Placement at nodes will maximize angular rotation and minimize linear displacement.

This device has been designed to meet stringent EMI and EMC requirements, and as such, the user should shield the I/O cabling and provide chassis ground connection to the IMU housing.

The IMU should not be subjected to contact with any fuels, lubricants, solvents, or their vapors.

**Figure 4. Accelerometer and Gyro Sensor Mounting**

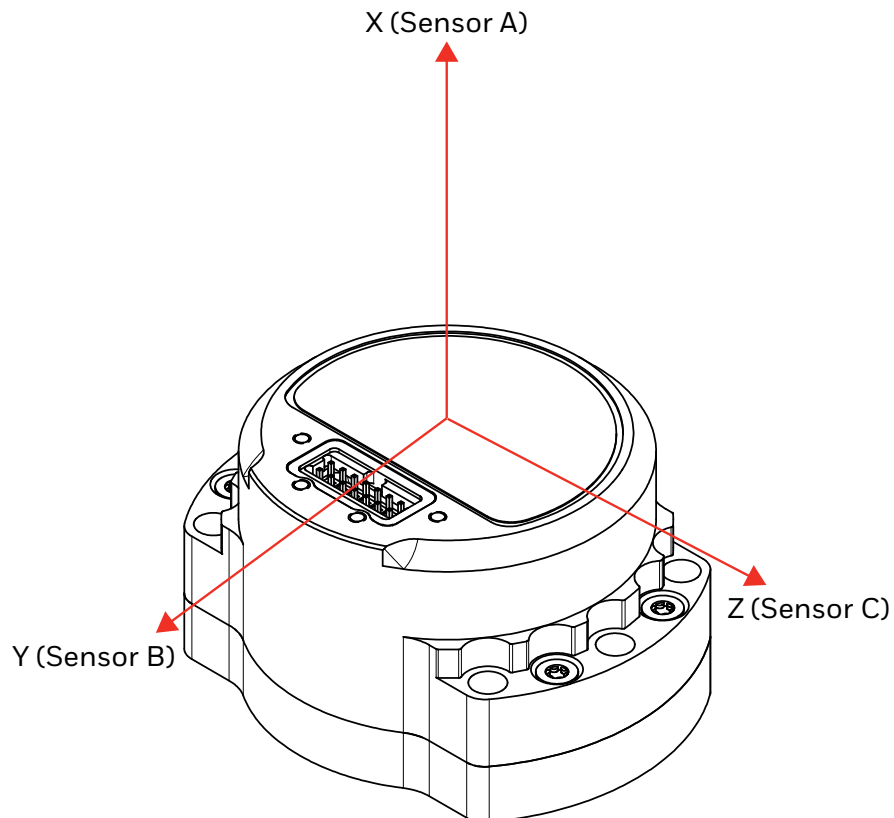
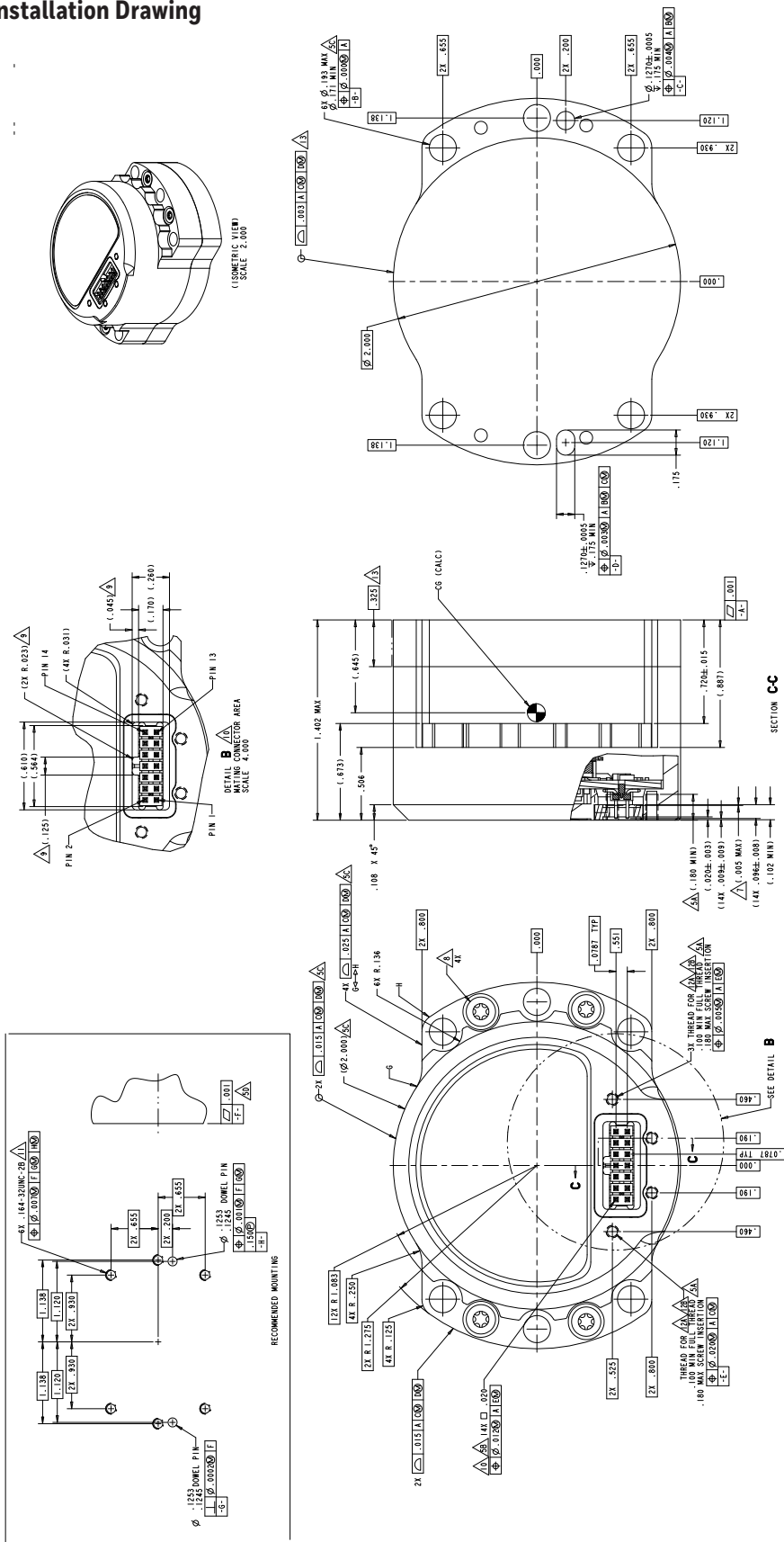

Figure 5. Installation Drawing



Dimensioning and Tolerancing IAW ANSI Y14.5M-1982.  
All Dimensions are in Inches  
STP File Available from Honeywell

- 4 - MOUNT IAW ON DATUM A SURFACE ONLY
- 5 - MAX SCREEN EXTENSION .180 FROM TOP SURFACE. .100 MIN SCREEN INSERTION RECOMMENDED
- 6 - DO NOT SOLDER INTERCONNECT. SEAL INTEGRITY CAN BE COMPROMISED
- 7 - MOUNTING SURFACE MUST BE FLAT
- 8 - MOUNTING SURFACE MUST BE ELECTRICALLY GROUND
- 9 - THIS ASSEMBLY IS ELECTROSTATIC SENSITIVE (ESDS). HANDLING, TESTING AND PACKAGING IAW PC200-94, CATEGORY 2
- 10 - NO POTTING ALLOWED ABOVE SURFACE INDICATED. MAX PIN WICKING OF .500 (1.025 TOTAL WICKING) ABOVE SURFACE INDICATED
- 11 - A RETING FEATURE IS PROVIDED TO ADDRESS MISORIENTATION OF CONNECTOR INTERFACE. IMPROPER ORIENTATION CAN CAUSE IAW DAMAGE
- 12 - DEVICE CONNECTOR SAMTEC PART NUMBER WPM-107 SERIES. MATES WITH SAMTEC CLT SERIES CONNECTOR. SAMTEC PART NUMBER CLT-107-02-00 OR CLT-107-02-03
- 13 - MOUNT DEVICE WITH FOUR .164-32UNC-2B (100%) MIN TENSILE STRENGTH TORQUED TO 25 IN-LBS MIN. 32 IN-LBS RECOMMENDED
- 14 - .050 PALLACE THREAD FROM .048-.053 MIN OR .071 .073 TREAD FROM PROSPERITY TO
- 15 - .050 PALLACE CORP. MADISON HEIGHTS, MI TREAD TOOLING, GAGING AND GAGE CERTIFICATION AVAILABLE
- 16 - REFERENCE ONLY - TORQUE SCREWS TO 4.25 IN-LBS MAX
- 17 - PROFILE TOLERANCE APPLIES OVER DIMENSION SHOWN
- 18 - DIMENSIONS CONTROLLED BY SUB-ASSEMBLY DRAWINGS

## Export Guidance

All technology that leaves the United States is subject to export regulations. This manual contains technology that has an Export Commodity Classification of ECCN 7E994 with associated country chart control code of AT1. This technology generally will not require a license to be exported or re-exported. However, if you plan to export this item to an embargoed or sanctioned country, to a party of concern, or in support of a prohibited end-use, you may be required to obtain a license.

## Contact Us

For more information, email [imu.sales@honeywell.com](mailto:imu.sales@honeywell.com)  
or contact us on our website [aerospace.honeywell.com/HG4930](https://aerospace.honeywell.com/HG4930)

### For more information

[aerospace.honeywell.com/HG4930](https://aerospace.honeywell.com/HG4930)

### Honeywell Aerospace

1944 East Sky Harbor Circle  
Phoenix, Arizona 85034  
+1 (800) 601 3099  
[aerospace.honeywell.com](https://aerospace.honeywell.com)

N61-1775-000-000 | 05/17  
© 2017 Honeywell International Inc.

**Honeywell**